

Models 441-57S

Regulator

SENSUS

Installation and Maintenance Instructions

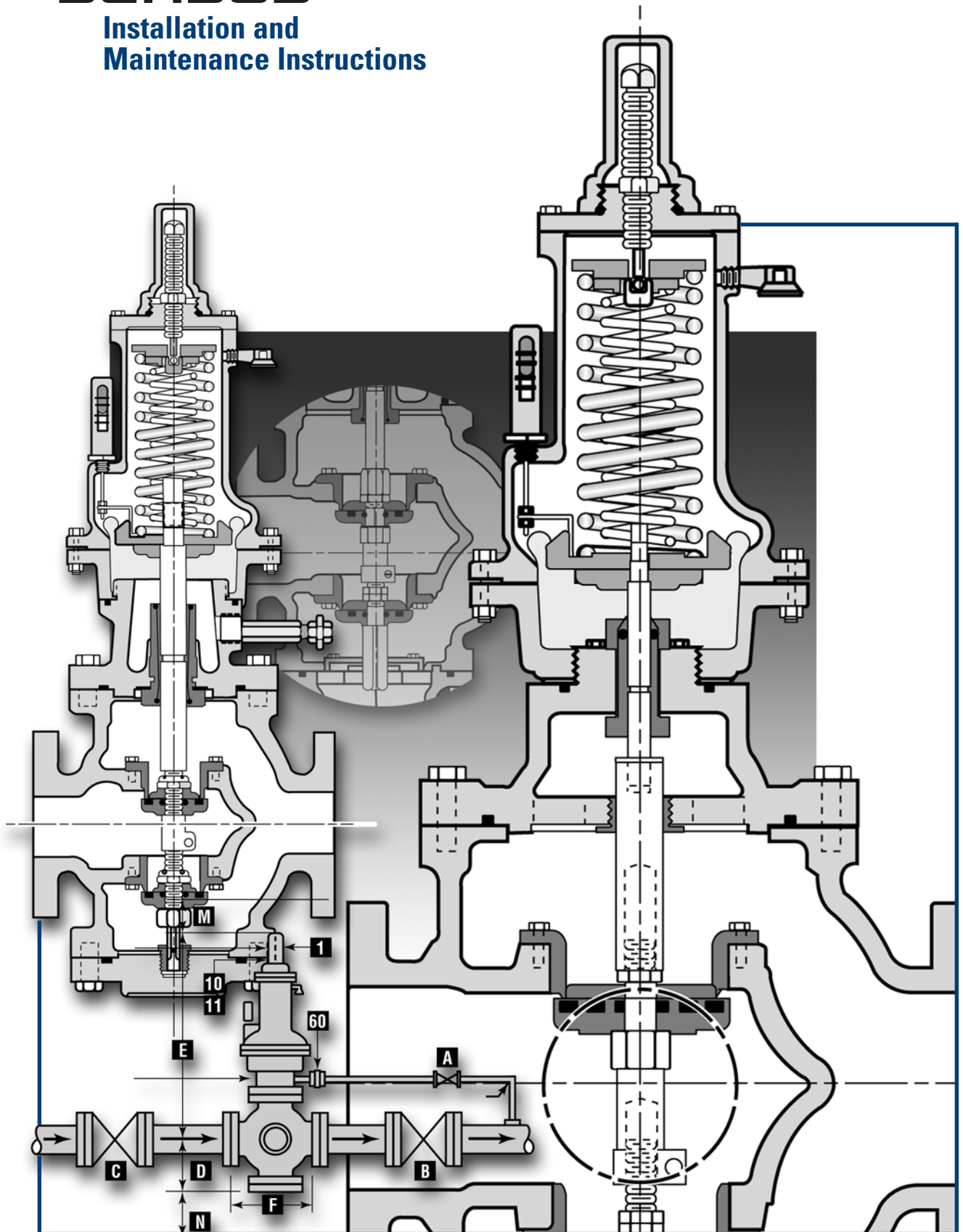

The Model 441-57S Regulator is an excellent general purpose gas pressure regulator for larger loads. Use it for natural gas, air, dry CO₂, propane, butane, and other gases.

Installation and Start-Up

1. Thoroughly purge inlet piping to remove dirt and debris that could damage the regulator or impair its operation. If this cannot be done, a filter or strainer should be installed ahead of the regulator (see Catalog RDS 1498, Regulator Pressure Ratings). Make certain that inside of regulator and piping are free of dirt, foreign matter, and other debris.
2. Install the regulator. Make certain flow through the regulator is in the correct direction. High pressure connects to the inlet side. Be sure that shipping screens or covers, if used, are removed.

On flanges, tighten bolts evenly. On screwed connections, apply pipe dope to male threads only.

Where required, the regulator may be inverted.

CAUTION

It is the user's responsibility to assure that all regulator vents and/or vent lines exhaust to a non-hazardous location away from ANY POTENTIAL sources of ignition.

Where vent lines are used, it is the user's responsibility to assure that each regulator is individually vented and that common vent lines ARE NOT used.

3. The vent connection is an escape path for flammable gas and it must be located and/or piped so that potential discharge occurs in a safe area away from buildings, open flames, collection areas, arcing devices, etc.

Regulators that are installed indoors or in a non-vented area must be vented to the outside. Simply run vent piping from the regulator vent connection to a non-hazardous location on the outside away from any potential sources of ignition. The vent piping must be connection size or larger and piped to a safe area.

The outlet of the vent piping must allow for the free and unobstructed passage of air and gas and must be protected against the potentials listed in the instructions.
4. For outdoor installations, it is recommended that the regulator be installed so that the regulator vent faces downward to avoid the potential for water or other foreign matter entering the regulator and interfering with proper operation of the regulator.
5. Install the control line. Run it from the Union shown at 60 on the regulator to the control connection in the outlet piping. The control line should be no less than 1/2" in size. It should be sturdy with adequate protection against breakage (regulators go wide open if the control line is broken). Pitch it to drain away from the regulator, free of moisture pockets. The regulator will work to deliver the pressure (for which it

Maximum Inlet Pressures

Regulator Body Type	Body Materials	Maximum Inlet Pressure
2" Screwed	Cast Iron	250 psi
Flanged ANSI 125	Cast Iron	175 psi*
Flanged ANSI 250	Ductile Iron	575 psi*
Flanged ANSI 300	Cast Steel	720 psi *
Flanged ANSI 600	Cast Steel	1000 psi*

*Carefully note the following exceptions to the above, based on valve size:

Body Size	Valve	Maximum Inlet Pressure
6"	4-1/4"	150 psi
6"	3" reduced	300 psi
4"	3"	
6"	2-1/8" reduced	500 psi
4"	2-1/8" reduced	
3"	2-1/8"	

Valve material selection is limited by inlet pressure and differential.

Valve Material	Maximum Inlet Pressure	Maximum Pressure Differential
Buna-N	575 psi	250 psi
Poly-U Red	720 psi	400 psi
Poly-U Tan	1200 psi	600 psi

is adjusted) at that point in the piping where the control connection is located.

In general, the control connection should be at least eight pipe diameters downstream from the regulator and should be in as straight a run of pipe as possible where turbulence is at a minimum. Keep clear of elbows, valves, and other causes of excessive turbulence.

The control connection should be clean and smooth inside the pipe to minimize turbulence. It should be free of rough edges, welding "icicles", etc. It should be located on the top or side of the pipe, not on the bottom. Where outlet piping increases in size near the regulator, it is generally preferable to locate the connection to the larger size piping.

The Union 60 contains a small orifice (approximately 1/16" diameter). This orifice should not be removed. Also, make certain it is open and free of foreign material.

- 6 Check all connections for leaks.

CAUTION

Turn gas on very slowly. If an outlet stop valve is used, it should be opened first. Do not overload the diaphragm with a sudden surge of inlet pressure. Monitor the outlet pressure during start-up to prevent an outlet pressure overload.

- Put the regulator into operation as follows:
 - Slowly open downstream control line valve (A).
 - Slowly open downstream block valve (B).
 - Very slowly open upstream block valve (C).
- Set adjusting screw **10** for the required outlet pressure. Turn it clockwise to increase the pressure and counterclockwise to decrease it. Only make this adjustment when gas is actually flowing through the regulator. After adjustment is complete, locknut **11** should be tightened firmly and seal cap **1** replaced.
- To shut down, carefully close valves (C), (B), and (A) in that order.

CAUTION

- Keep pipe dope and all other foreign substances out of the control line.
- Never install any type of automatic shut-off device, which closes completely, between the regulator outlet and the downstream control line connections.
- The vent must be positioned to protect against flooding, drain water, ice formation, traffic, tampering, etc. The vent must be protected against nest building animals, bees, insects, etc. to prevent vent blockage and minimize the chances for foreign material from collecting in the vent side of the regulator diaphragm.

Servicing and Adjustment

General Notes (See illustration on pages 5 – 7)

- Make sure the regulator is entirely depressurized before servicing.
- A quick visual inspection of the valve can be made by removing inspection plates **38** from the sides of the body. These also provide greatly improved access to the valve when servicing or adjusting.
- Carefully note location and position of disassembled parts to be certain reassembly is correct. Inspect each one carefully and replace those that are worn or damaged or otherwise unsatisfactory.
- The diaphragm **20**, the springs **14**, and all other parts from the diaphragm up (except the **24** stem) are fully interchangeable with the Model 461-57S Regulator. Valve and body parts are interchangeable with other 441 Regulators (441-S, 441-X57, 441-VPC.).

- Use lubricants sparingly and with care to avoid exposing tacky surfaces to the gas stream. Such surfaces could cause dirt accumulation on close clearance parts.

Use moly or silicone type lubricants.

Avoid the use of petroleum base types.

Lubricate the stem **24**, the guide **50h** and stem O-ring **23** with dry silicone lubricant to help assure free movement and a tight seal.

An application of silicone base lubricant to the other O-rings and the tetraseals in the regulator will also help assure their tightness.

- There is **one screwed connection that must be loose.**

Carefully note which one it is. All other connections must be firm and tight.

On 2" and 3" regulators, the loose connection is between parts **50e** and **24**.

On 4" and 6" regulators, the loose connection is between parts **50i** and **24**.

This loose connection should be screwed together until it bottoms, then be **backed off 1/2 to 1 full turn.**

- When replacing orifices, tighten cap screws **26** evenly and carefully to avoid stripping female threads in body casting.
- When changing to different size valve in 4" and 6" regulators, be sure to use the correct travel stop (Ill. No. 54). For identification, last digit of part number is recessed into one end of travel stop.

CAUTION

Regulators are pressure control devices with numerous moving parts subject to wear which is dependent upon particular operating conditions. To assure continuous satisfactory operation, a periodic inspection schedule must be adhered to with the frequency of inspection determined by the severity of service and applicable laws and regulations.

To Remove Valves

- Remove seal cap **1**, back off adjusting screw **10**, remove housing cover **5** and spring **14** (also, **14a** and **14b** if used).
- Remove bottom plate **33**, and side plates **38**.
- Insert an Allen wrench through side inspection opening and loosen Allen screw **50g**.
- Unscrew lower valve assembly and remove through bottom opening. (**50h** unscrews from **50e**).
- Unscrew upper valve assembly and remove through side opening. (**50e** or **50i** unscrews from **24**).

Note:

- a. If upper valve assembly is too large to remove through side opening, then remove it through bottom opening by also removing outlet orifice **29**, (remove cap screws **26** to remove orifice, and if tight, jack out using cap screws in jacking holes).
- b. Entire valve assembly may be removed intact through bottom opening by also removing orifice **29**. This method leaves the lock-up adjustment undisturbed.
- c. Use care with orifice O-ring **27**.
6. To disassemble upper and/or lower valve assembly, remove nuts **50a**.

To Replace and Adjust Valves

1. Assemble upper valve assembly (parts **50a**, **50b**, **50c**, **50d**, **50e**, **50f**, **50g**, **50i**), and lower valve assembly (parts **50a**, **50b**, **50c**, **50d**, **50h**). Firmly tighten nuts **50a**. Also, **50i** should be firmly tightened against **50a**.
2. Insert upper valve assembly and screw into place. Screw **50e** or **50i** into **24** until it bottoms. **Then back off 1/2 to 1 turn - this is important.**
3. If orifice **29** was removed, reinstall it.
4. Insert lower valve assembly and screw into place by a few turns (**50h** screws into **50e**).
5. Turn upper valve assembly so Allen screw **50g** is accessible through side inspection opening.
6. Make the valve lock-up adjustment as follows:
 - a. Hold upper valve against its seat. This can be done by hand, reaching through side inspection opening.
 - b. While holding the upper valve against its seat, screw lower valve assembly upwards until the lower valve also touches its seat. When both upper and lower valves are touching their seats, they are correctly adjusted for tight lock-up.
- c. Firmly tighten Allen screw **50g**. This locks the adjustment by evenly and tightly locking **50h** and **50e** together.

Note: If the entire valve assembly was removed intact and Allen screw **50g** has not been loosened, the assembly may be reinstalled without making the lock-up adjustment.

7. Screw entire valve assembly up (**50e** or **50i** screws into **24** until it bottoms). Then **back off 1/2 to 1 turn – this is important.**
8. Replace side plates **38**.
9. Replace bottom plate **33**. Match bottom end of **50h** into **31** and/or **32**, then turn bottom plate either way to first matching bolt hole position.

To Remove Orifices

1. Remove orifice **29** per applicable steps 1 through 5 under section “To Remove Valves”.
2. Remove inlet orifice **28** as follows:

- a. Remove seal cap **1**, back off adjusting screw **10**, remove housing cover **5**, and remove spring.
- b. Remove bottom plate **33** and then unscrew valve assembly by grasping **50h** and turning. (**50e** or **50i** unscrews from **24**).
- c. Remove diaphragm case assembly by first opening union **60** and removing cap screws **34**.
- d. Remove cap screws **26** and remove inlet orifice **28**. If orifice is tight, jack out cap screws in jacking holes. Use care with O-ring **27**.
- e. When replacing diaphragm assembly, the threaded connection between **24** and **50e** or **50i** should be screwed together until it bottoms. Then **backed off 1/2 to 1 turn - this is important.**

To Change Spring

1. Remove seal cap **1**, back off adjusting screw **10**, remove housing cover **5**, and remove spring.
2. Insert the new spring. Be sure it nests correctly into part **19** and travel indicator bracket **45k** is in place. Also, make a visual inspection of diaphragm **20** before inserting the spring to be sure the roll-out is uniform and in place. (Use a flashlight if necessary).
3. Complete steps 7, 8, and 9 under “To Assemble 441-57S”.

To Service Diaphragm

1. Remove seal cap **1**, back off adjusting screw **10**, remove housing cover **5**, and remove spring **14**. If used, also remove spring **14a** and **14b**.
2. Remove bolts **42**. Then carefully remove upper diaphragm case **8**.
3. Turn diaphragm assembly counterclockwise until **24** unscrews from **50e** or **50i**, then remove assembly and inspect diaphragm.
4. If a new diaphragm **20** is required, remove nut **16** and disassemble.
5. When reassembling, **be sure that fabric side of diaphragm 20 will be toward the vent side of the regulator and the rubber side of diaphragm toward the pressure side. The gasket is always placed on the spring side of the diaphragm.**
6. Screw diaphragm assembly back into place (**24** screws into **50e** or **50i** until it bottoms). Then **back off 1/2 to 1 turn – this is important.**
7. Fold roll into roll-out diaphragm and then carefully reinstall upper diaphragm case **8**. Diaphragm must not be pinched between upper and lower cases **8** and **40** or **40a**. Also, roll-out loop must be uniformly full and even. It should be in place as shown on the cross-section drawing. Tighten bolts **42** evenly.
8. Replace spring, etc., per steps 6 thru 9 under “To Assemble 441-57S”.

To Assemble 441-57S

1. Install orifice **28** through top opening.
2. Install valve assembly and orifice **29** per applicable steps 1 through 6 under "To Replace and Adjust Valves" (except that **50e** or **50i** does not yet screw into **24**).
3. Install centerpiece and lower diaphragm case **36** and **40** or **40a**.
4. Install diaphragm assembly and case per steps 5 through 7 under "To Service Diaphragm".
5. Replace bottom plate **33**. Match bottom end of **50h** into **31** and/or **32**, then rotate bottom plate either way to the first matching bolt hole position.
6. Inset the spring. Be sure it nests correctly onto part **19** and travel indicator bracket **45k** is in place. Also, make a visual inspection of diaphragm **20** before inserting the spring to be sure the roll-out is uniform and in place (use a flashlight if necessary).
7. Insert top spring button **12**. Be sure it is nested correctly on the spring. Also, make sure that ball **13** is in place.
8. Install housing cover **5**. Be sure the lower end of adjusting screw **10** fits into the hole in button **12**.
9. Set adjusting screw **10** for desired outlet pressure. Firmly tighten nut **11** and replace seal cap **1**.

Over Pressurization Protection

Protection must be provided for the downstream piping system and the regulator's low pressure chambers to assure against the potential over pressurization due to a regulator malfunction or a failure of the regulator to lock-up. The allowable over pressurization is the lowest of the maximum pressures permitted by federal codes, state codes, Sensus bulletin RDS-1498, or other applicable standards. The Method of providing over pressure protection could be a relief valve, a monitor regulator, a shut-off device or any similar device.

Temperature Limits

The Model 441-57S Regulator can be used for flowing temperatures from -20°F to 150°F.

Buried Service

The 441-57S Regulators ARE NOT recommended for buried service.

Model 441-57S General Assembly 2" and 3" Models

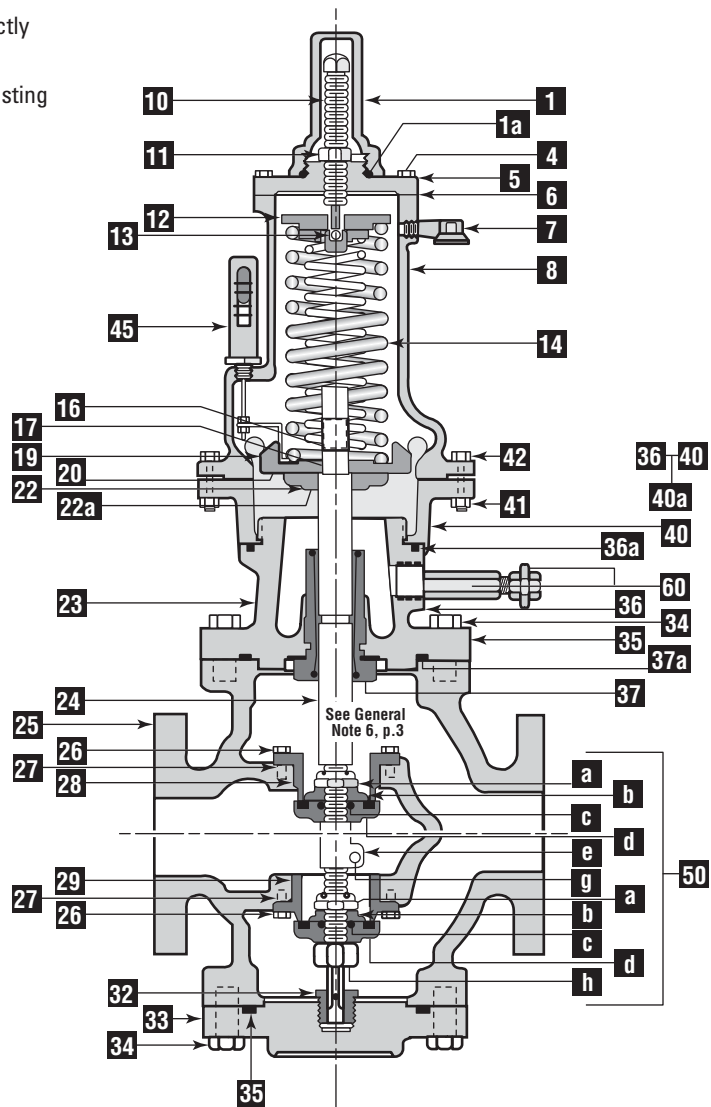
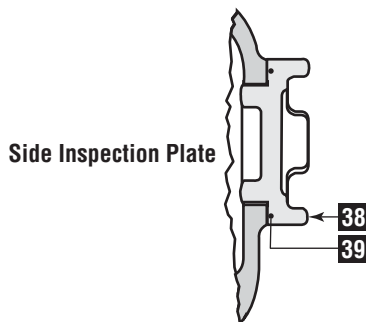

Typical Arrangements and Dimensions Model (Indoor or Outdoor Installation)

Regulator Body Type	F (Face to Face, in.)			
	2" Pipe	3" Pipe	4" Pipe	6" Pipe
Screwed	10	—	—	—
Flanged ANSI 125	10	11 ¾	13 ¾	17 ¾
Flanged ANSI 250	10 ½	12 ½	14 ½	18 ½
Flanged ANSI 300	10 ½	12 ½	14 ½	18 ½
Flanged ANSI 600	11 ¼	13 ¼	15 ½	20

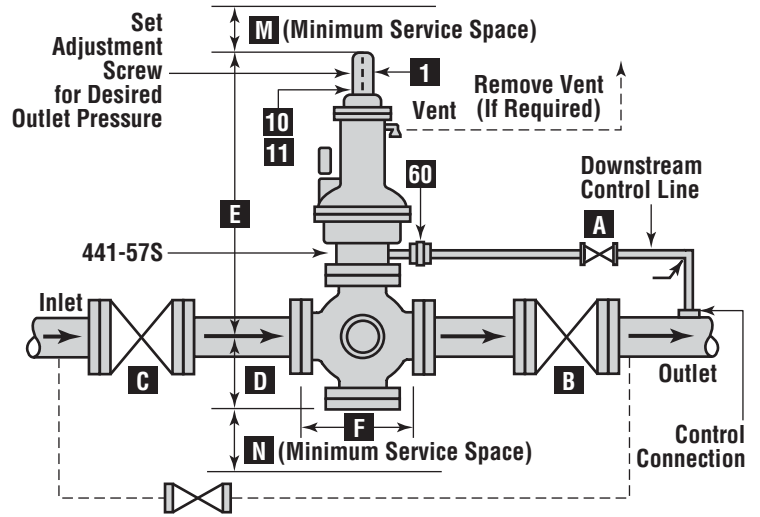

Model 441-57S General Assembly 4" Model

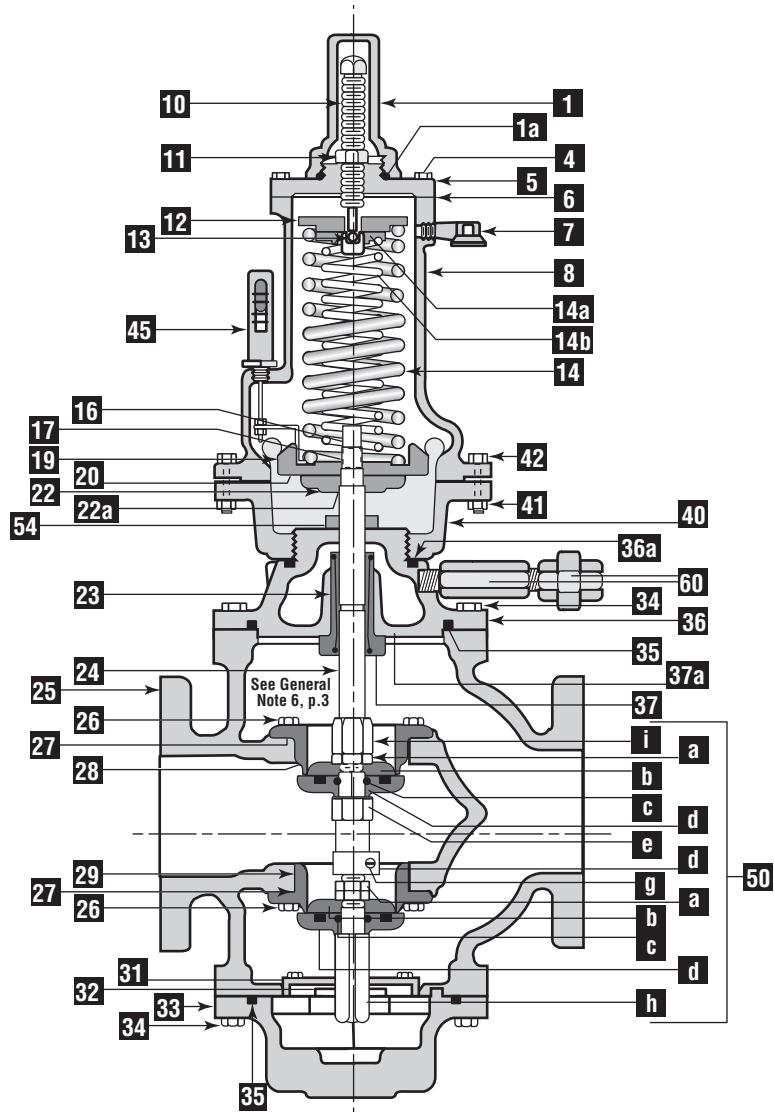
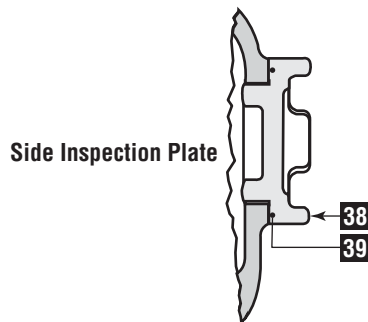

Installation and Maintenance Instructions

Model 441-57S Regulator



Dimensions in Inches

	D	E	M	N
2" Pipe	6	24	5	7
3" Pipe	6	24	5	7
4" Pipe	9½	25	5	8
6" Pipe	12	28½	5	14

Spring Ranges

Outlet Pressure Min. to Max	Spring Color	Nominal Diaphragm Size (I.D.)
3 to 6 psi	Yellow	5" all ranges
5 to 9 psi	Gray	
7-1/2 to 15 psi	Blue	
12-1/2 to 30 psi	Red	
25 to 55 psi	Brown	
50 to 75 psi	Black	
70 to 100 psi	Brown plus White*	

* White colored spring is nested within brown

Model 441-57S General Assembly 6" Model

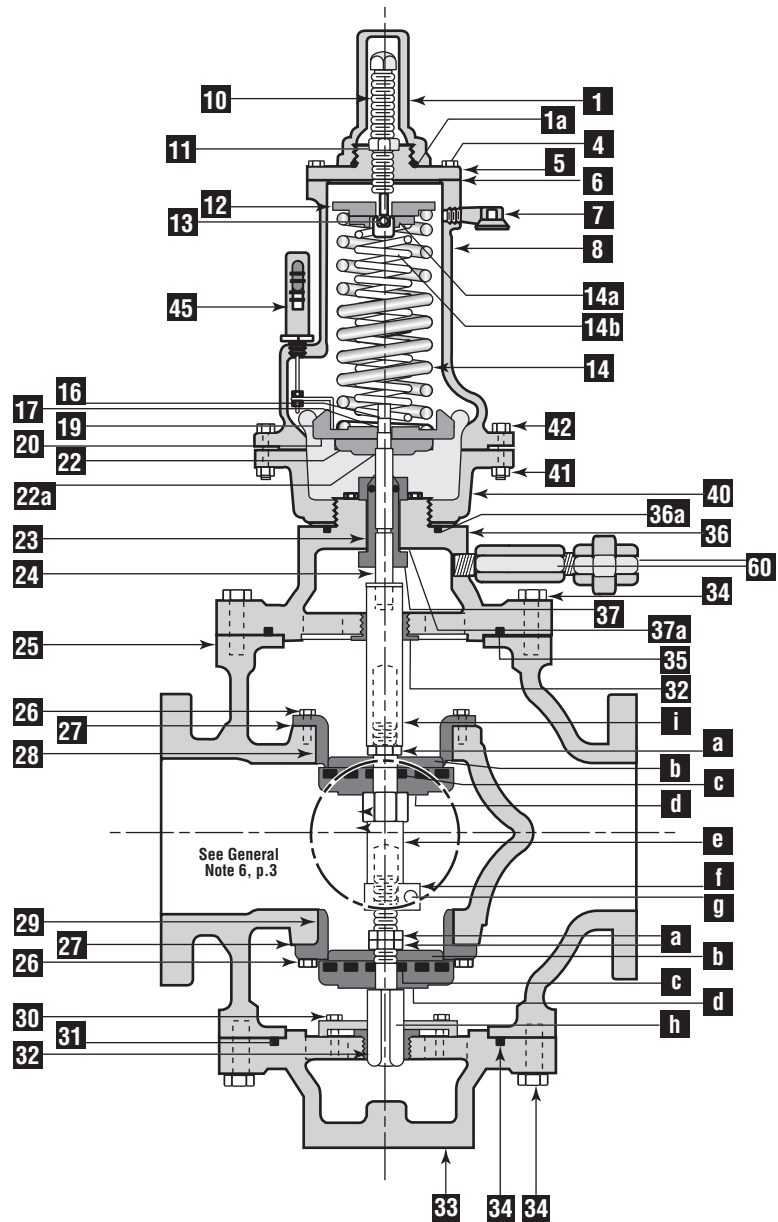
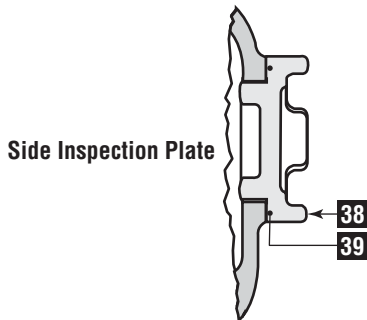

Model 441-57S Condensed Parts List

2", 3", 4", and 6" Models

Illustration Number	Description	Part Number
1a	Tetraseal (or O-Ring), 1-3/4" x 2"	904092
4	Hex Cap Screw, 5/16" – 18 x 1", 120,000 tensile, 8 used	910030
6	Housing Cover Gasket	091-00-066-30
7	Vent Cap, 1/4 NPT	137-02-505-02
10	Spring Adjustment Screw	090-16-007-02
11	Hex Steel Jam Nut, 5/8" – 11	921407
13	Thrust Bearing, 3/8" dia. stainless steel ball	930510
14	Spring, Yellow 3 to 6 psi	091-00-021-05
	Spring, Gray 5 to 9 psi	091-00-021-04
	Spring, Blue 7-1/2 to 15 psi	091-00-021-03
	Spring, Red 12-1/2 to 30 psi	091-00-021-02
	Spring, Brown 25 to 55 psi	091-00-021-01
	Spring, Black 50 to 75 psi	091-00-021-00
	Spring, Brown plus White 70 to 100 psi	
	Brown outer spring	091-00-021-01
	White inner spring	091-00-021-08
16	Hex Steel Nut 5/8"	905993
17	Split Lockwasher 5/8"	932531
19	Diaphragm Plate, upper	091-00-010-00
20	Diaphragm, 5" Roll-Out	091-00-350-00
41	Hex Steel Nut, 3/8" – 16, 8 used	920853
42	Hex Steel Bolt, 3/8" – 16 x 1-3/4" Lg., 8 used	910058
45	Travel Indicator Assembly 5/8" scale (1-1/2", 1-3/4", 2-1/8" valves)	091-00-365-75
	1" scale (3" valves)	091-00-365-77
	1-1/4" scale (4-1/4" valves)	091-00-365-79
60	1/2" NPT Nipple, Orifice Plug and Steel Union Assembly	090-16-361-01
90	Nameplate	090-00-086-05
91	Nameplate, round	090-16-086-00
92	Rd. Hd. Type U Drive Screw, #4 x 3/16" Lg.	903004
93	Rd. Hd. Machine Screw, 6-32 x 1/4" Lg.	914402

2" and 3" Models

Illustration Number	Description	Part Number
22	Lower Diaphragm Plate	091-00-022-00
22a	O-Ring, 5/8" x 3/4"	902922
23	O-Ring, 11/16" x 7/8"	934013
24	Diaphragm Connecting Screw, stainless steel	090-16-058-00

2" Models

Illustration Number	Description	Part Number
26	Hex Cap Screw, 1/4" – 20 x 1/2" Lg., 120,00 tensile	910001
27	O-Ring for Orifices	904832
28	1-3/4" Inlet Orifice, plated steel	090-16-028-00
	1-3/4" Inlet Orifice, stainless steel	090-16-028-50
	1-1/2" Inlet Orifice, plated steel	090-16-028-01
	1-1/2" Inlet Orifice, stainless steel	090-16-028-51
26	1-3/4" Outlet Orifice, plated steel	090-16-029-00
	1-3/4" Outlet Orifice, stainless steel	090-16-029-50
	1-3/4" Outlet Orifice, plated steel	090-16-029-01
	1-3/4" Outlet Orifice, stainless steel	090-16-029-51

3" Models

Illustration Number	Description	Part Number
26	Hex Cap Screw, 1/4" – 20 x 1/2" Lg., 120,00 tensile	910001
27	O-Ring for Orifices	950818
28	2-1/8" Inlet Orifice, plated steel	090-20-028-00
	2-1/8" Inlet Orifice, stainless steel	090-20-028-50
	1-3/4" Inlet Orifice, plated steel	090-20-028-02
	1-3/4" Inlet Orifice, stainless steel	090-20-028-52
29	1-1/2" Inlet Orifice, plated steel	090-20-028-03
	1-1/2" Inlet Orifice, stainless steel	090-20-028-53
	2-1/8" Outlet Orifice, plated steel	090-20-029-00
	2-1/8" Outlet Orifice, stainless steel	090-20-029-50
	1-3/4" Outlet Orifice, plated steel	090-20-029-02
	1-3/4" Outlet Orifice, stainless steel	090-20-029-52
	1-1/2" Outlet Orifice, plated steel	090-20-029-03
	1-1/2" Outlet Orifice, stainless steel	090-20-029-53

2" and 3" Models

Illustration Number	Description	Part Number
32	Guide Bushing with Pin, brass	090-16-385-01
	Guide Bushing with Pin, stainless steel	090-16-385-03
34	Hex Cap Screw, 1/2" – 13 x 1-1/4"	910106
35	Tetraseal (or O-Ring), 4-3/8" x 4-5/8"	904085
36	Tetraseal (or O-Ring), 3" x 3-1/4"	904084
37	Centerpiece Stem Bushing	090-16-373-00
37a	Aluminum Seal Ring	090-26-178-00
39	Tetraseal (or O-Ring), 3-1/4" x 3-1/2"	904078

Installation and Maintenance Instructions

Model 441-57S Regulator



4" Models

Illustration Number	Description	Part Number
22	Lower Diaphragm Plate	091-00-022-01
22a	O-Ring, 5/8" x 3/4"	902922
23	O-Ring, 11/16" x 7/8"	934013
24	Diaphragm Connecting Screw, stainless steel	090-16-058-00
26	Hex Cap Screw, 3/8" – 16 x 3/4" Lg., 120,000 tensile	910053
27	O-Ring for Orifices	905583
28	3" Inlet Orifice, plated steel	090-22-028-00
	3" Inlet Orifice, stainless steel	090-22-028-50
	2-1/8" Inlet Orifice, plated steel	090-22-028-02
	2-1/8" Inlet Orifice, stainless steel	090-22-028-52
	1-3/4" Inlet Orifice, plated steel	090-22-028-01
	1-3/4" Inlet Orifice, stainless steel	090-22-028-51
29	3" Outlet Orifice, plated steel	090-22-029-00
	3" Outlet Orifice, stainless steel	090-22-029-50
	2-1/8" Outlet Orifice, plated steel	090-22-029-02
	2-1/8" Outlet Orifice, stainless steel	090-22-029-52
	1-3/4" Outlet Orifice, plated steel	090-22-029-01
	1-3/4" Outlet Orifice, stainless steel	090-22-029-51
30	Hex Cap Screw, 3/8" – 16 x 1" Lg.	910055
31	Spin Stop Plate	090-22-040-01
32	Guide Bushing, brass	090-22-074-00
	Guide Bushing, stainless steel	090-22-074-01
34	Hex Cap Screw, 5/8" – 11 x 1-1/2"	910157
	Hex Cap Screw, 5/8" – 11 x 1-3/4" for ductile bottom plate	910158
35	Tetraseal (or O-Ring), 6-1/4" x 6-1/2"	904080
36a	Tetraseal (or O-Ring), 4" x 4-1/4"	904084
37	Centerpiece Stem Bushing	090-16-373-00
37a	Aluminum Seal Ring	090-26-178-00
39	Tetraseal (or O-Ring), 4-1/4" x 4-1/2"	904083

6" Models

Illustration Number	Description	Part Number
22	Lower Diaphragm Plate	091-00-022-02
22a	O-Ring, 5/8" x 3/4"	902922
23	O-Ring, 11/16" x 7/8"	934013
24	Diaphragm Connecting Stem, stainless steel	090-22-058-00
26	Hex Cap Screw, 3/8" – 16 x 1" Lg., 120,000 tensile	910055
27	O-Ring for Orifice	906301
28	4-1/4" Inlet Orifice, plated steel	090-24-028-00
	4-1/4" Inlet Orifice, stainless steel	090-24-028-02
	3" Inlet Orifice, plated steel	090-24-028-10
	3" Inlet Orifice, stainless steel	090-24-028-12
	2-1/8" Inlet Orifice, plated steel	090-24-028-22
	2-1/8" Inlet Orifice, stainless steel	090-24-028-24
29	4-1/4" Outlet Orifice, plated steel	090-24-029-00
	4-1/4" Outlet Orifice, stainless steel	090-24-029-02
	3" Outlet Orifice, plated steel	090-24-029-10
	3" Outlet Orifice, stainless steel	090-24-029-12
	2-1/8" Outlet Orifice, plated steel	090-24-029-22
	2-1/8" Outlet Orifice, stainless steel	090-24-029-24
30	Hex Cap Screw, 3/8" – 16 x 1" Lg.	910055
31	Spin Stop Plate	090-24-040-01
32	Guide Bushing, stainless steel	090-24-074-01
34	Hex Cap Screw, 5/8" – 11 x 2"	910159
35	Tetraseal (or O-Ring), 7-3/4" x 8"	904088
36	Tetraseal (or O-Ring), 4" x 4-1/4"	904084
37	Centerpiece Stem Bushing	090-16-373-02
37a	Aluminum Seal Ring	090-26-178-00
39	Tetraseal (or O-Ring), 6" x 6-1/4"	904089

2" and 3" Models

Illustration Number	Description	Part Number
50	Valve Assembly, 1-3/4", brass trim, Polyurethane (Red, 65-75 Duro)	090-16-515-32
	Valve Assembly, 1-3/4", stainless steel trim, Polyurethane (Red, 65-75 Duro)	090-16-515-52
	Valve Assembly, 1-1/2", brass trim, Polyurethane (Red, 65-75 Duro)	090-16-515-33
	Valve Assembly, 1-1/2", stainless steel trim, Polyurethane (Red, 65-75 Duro)	090-16-515-53

Model 441-57S Condensed Parts List

3" Models

Illustration Number	Description	Part Number
50	Valve Assembly, 2-1/8", brass trim, Polyurethane (Red, 65-75 Duro)	090-20-515-40
	Valve Assembly, 2-1/8", stainless steel trim, Polyurethane (Red, 65-75 Duro)	090-20-515-60
50b	Valve Retainer, standard, stainless steel, 2-1/8"	090-20-018-30
	Valve Retainer, v-port wings, stainless steel, 2-1/8"	090-20-012-51
50d	Molded Valve, 2-1/8", Buna-N (Black, 50-55 Duro) all trim	090-20-315-00
	Molded Valve, 2-1/8", Polyurethane (Red, 65-76 Duro) all trim	090-20-315-02
	Molded Valve, 2-1/8", Polyurethane (Tan 85-95 Duro) all trim	090-20-315-03

2" and 3" Models

Illustration Number	Description	Part Number
50a	Valve Lock Nut, 5/8" – 18	090-16-034-00
50b	Valve Retainer, standard, steel, 1-3/4"	090-16-018-00
	Valve Retainer, standard, stainless steel, 1-3/4"	090-16-018-30
	Valve Retainer, v-port wings, stainless steel, 1-3/4"	090-16-012-53
	Valve Retainer, standard, steel, 1-1/2"	090-16-018-01
	Valve Retainer, standard, stainless steel, 1-1/2"	090-16-018-31
	Valve Retainer, v-port wings, steel, 1-1/2"	090-16-012-52
	Valve Retainer, v-port wings, stainless steel, 1-1/2"	090-16-012-55
50c	O-Ring, 5/8" x 13/16"	934012
50d	Molded Valve, 1-3/4", Buna-N (Black, 50-55 Duro) all trim	090-16-315-00
	Molded Valve, 1-1/2", Buna-N (Black, 50-55 Duro) all trim	090-16-315-01
	Molded Valve, 1-3/4", Polyurethane (Red, 65-75 Duro) all trim	090-16-315-02
	Molded Valve, 1-1/2", Polyurethane (Red, 65-75 Duro) all trim	090-16-315-03
	Molded Valve, 1-3/4", Polyurethane (Tan, 85-95 Duro)	090-16-315-05
50e	Molded Valve, 1-1/2", Polyurethane (Tan, 85-95 Duro) all trim	090-16-315-04
	Female Valve Stem, brass	090-16-116-00
50g	Female Valve Stem, stainless steel	090-16-116-01
	Adjustment Clamp Screw, Soc. Hd. Screw, 10 – 24 x 1/2" Lg.	903486
50h	Adjustment Clamp Screw, for 1-1/2" valve only	090-16-046-01
	Male Valve Stem, brass	090-16-016-01
	Male Valve Stem, stainless steel	090-16-016-02

4" Models

Illustration Number	Description	Part Number	
50	Valve Assembly, 3", brass trim Polyurethane (Red, 65-75 Duro)	090-22-515-40	
	Valve Assembly, 3", stainless steel trim, Polyurethane (Red, 65-75 Duro)	090-22-515-60	
	Valve Assembly, 2-1/8", brass trim, Polyurethane (Red, 65-75 Duro)	090-22-515-41	
	Valve Assembly, 2-1/8", stainless steel trim, Polyurethane (Red, 65-75 Duro)	090-22-515-61	
	Valve Assembly, 1-3/4", brass trim, Polyurethane (Red, 65-75 Duro)	090-22-515-42	
	Valve Assembly, 1-3/4", stainless steel trim, Polyurethane (Red, 65-75 Duro)	090-22-515-62	
	50a	Valve Lock Nut, 3/4" – 16	090-22-034-00
		Valve Retainer, standard, iron, 3"	090-22-018-03
		Valve Retainer, standard, stainless steel, 3"	090-22-018-00
		Valve Retainer, v-port wings, iron, 3"	090-22-012-20
50b	Valve Retainer, v-port wings, stainless steel, 3"	090-22-012-40	
	Valve Retainer, standard, iron, 2-1/8"	090-22-018-01	
	Valve Retainer, standard, stainless steel, 2-1/8"	090-22-018-31	
	Valve Retainer, v-port wings, iron, 2-1/8"	090-22-012-50	
	Valve Retainer, v-port wings, stainless steel, 2-1/8"	090-22-012-51	
	Valve Retainer, standard, stainless steel, 1-3/4"	090-22-018-34	
	50c	O-Ring, 13/16" x 1"	904173
50d	Molded Valve, 3", Buna-N (Black, 50-55 Duro) all trim	090-22-315-00	
	Molded Valve, 2-1/8", Buna-N (Black, 50-55 Duro) all trim	090-22-315-01	
	Molded Valve, 1-3/4", Buna-N (Black, 50-55 Duro) all trim	090-22-315-04	
	Molded Valve, 3", Polyurethane (Red, 65-75 Duro) all trim	090-22-315-02	
	Molded Valve, 2-1/8", Polyurethane (Red, 65-75 Duro) all trim	090-22-315-03	
	Molded Valve, 1-3/4", Polyurethane (Red, 65-75 Duro) all trim	090-22-315-05	
	Molded Valve, 3", Polyurethane (Tan, 85-95 Duro) all trim	090-22-315-08	
	Molded Valve, 2-1/8", Polyurethane (Tan, 85-95 Duro) all trim	090-22-315-07	
	Molded Valve, 1-3/4", Polyurethane (Tan, 85-95 Duro) all trim	090-22-315-06	

Installation and Maintenance Instructions

Model 441-57S Regulator



4" Models (continued)

Illustration Number	Description	Part Number
50e	Female Valve Stem, brass	090-22-016-40
	Female Valve Stem, stainless steel	090-22-016-41
50f	Adjustment Clamp Ring, brass	090-22-043-00
	Adjustment Clamp, Ring, stainless steel	090-22-043-02
50g	Adjustment Clamp Screw, Soc. Hd. Screw, 1/4" – 20 x 3/4" Lg.	903494
50h	Male Valve Stem, stainless steel	090-22-116-01
50i	Stem Extension, stainless	090-22-058-40
	Travel Stop, for 3" valves	090-22-040-51
54	Travel Stop, for 2-1/8" and 1-3/4" valves	090-22-040-55

6" Models

Illustration Number	Description	Part Number
50	Valve Assembly, 4-1/4", brass trim, Polyurethane (Red, 65-75 Duro)	090-24-515-40
	Valve Assembly, 4-1/4", stainless steel trim, Polyurethane (Red, 65-75 Duro)	090-24-515-60
	Valve Assembly, 3", brass trim, Polyurethane (Red, 65-75 Duro)	090-24-515-41
	Valve Assembly, 2-1/8", brass trim, Polyurethane (Red 65-75 Duro)	090-24-515-42
	Valve Assembly, 2-1/8", stainless steel trim, Polyurethane (Red, 65-75 Duro)	090-24-515-62
	Valve Lock Nut	015-31-034-70
50a	Valve Lock Nut, 5/8" – 18, for 2-1/8" reduced valve only	090-16-034-00
	Valve Retainer, standard, iron, 4-1/4"	090-24-018-00
50b	Valve Retainer, standard, stainless steel, 4-1/4"	090-24-018-02
	Valve Retainer, v-port wings, stainless steel, 4-1/4"	090-24-012-40
	Valve Retainer, standard, iron, 3"	090-24-018-21
	Valve Retainer, standard, stainless steel, 3"	090-24-018-22
	Valve Retainer, standard, stainless steel, 2-1/8"	090-20-018-30
	Valve Retainer, v-port wings, stainless steel, 2-1/8"	090-20-012-51
50c	O-Ring, 1-3/16" x 1-3/8"	904174
	O-Ring, 5/8" x 13/16" for 2-1/8" reduced valve only	934012

6" Models (continued)

Illustration Number	Description	Part Number
50d	Molded Valve, 4-1/4", Buna-N (Black, 50-55 Duro) all trim	090-24-315-00
	Molded Valve, 3", Buna-N (Black, 50-55 Duro) all trim	090-24-315-01
	Molded Valve, 2-1/8", Buna-N (Black, 50-55 Duro) all trim	090-20-315-00
	Molded Valve, 4-1/4", Polyurethane (Red, 65-75 Duro) all trim	090-24-315-02
	Molded Valve, 3", Polyurethane (Red, 65-75 Duro) all trim	090-24-315-03
	Molded Valve, 2-1/8", Polyurethane (Red 65-75 Duro) all trim	090-20-315-02
	Molded Valve, 4-1/4", Polyurethane (Tan, 85-95 Duro) all trim	090-24-315-05
	Molded Valve, 3", Polyurethane (Tan, 85-95 Duro) all trim	090-24-315-04
	Molded Valve, 2-1/8", Polyurethane (Tan, 85-95 Duro) all trim	
	Female Valve Stem, stainless steel	090-24-016-01
	Female Valve Stem, stainless steel for 2-1/8" reduced valve only	090-24-016-11
	Adjustment Clamp Ring, stainless steel	090-24-043-02
50f	Adjustment Clamp Ring, stainless steel for 2-1/8" reduced valve only	090-16-043-03
	Adjustment Clamp Screw, Soc. Hd. Screw, 5/16" – 18 x 1" Lg.	903498
50g	Adjustment Clamp Screw, for 2-1/8" reduced valve only	903494
	Male Valve Stem, stainless steel	090-24-116-01
50h	Male Valve Stem, brass for 2-1/8" reduced valve only	090-24-116-10
	Stem Extension, stainless	090-24-062-04
50i	Valve Stem Hex Extension, stainless, for 2-1/8" reduced valve only	090-16-062-11
54	Travel Stop, for 4-1/4" valves	090-22-040-50
	Travel Stop, for 3" valves	090-22-040-52
	Travel Stop, for 2-1/8" valves	090-22-040-56

Models 441-57S Regulator

Installation and Maintenance Instructions



805 Liberty Boulevard
DuBois, PA 15801
800-375-8875
Fax: (814) 375-8460
www.sensus.com/gas

Maximum Emergency Pressure

The Maximum emergency pressure that the inlet side of the Model 441-57S Regulator may be subjected to under abnormal conditions without causing damage to the regulator is:

Cast Iron Body Maximum Inlet Pressure + 25 psi

Ductile Iron Body Maximum Inlet Pressure + 60 psi

Cast Steel Body Maximum Inlet Pressure + 100 psi

If pressure exceeds the above values the regulator must be removed from service and inspected. Damaged or otherwise unsatisfactory parts must be repaired or replaced before returning the regulator to service.

The maximum pressure which the diaphragm may be subjected to under abnormal conditions without causing internal damage is the set-point + 25 psi. If the pressure on the diaphragm exceeds set-point by more than + 25 psi, the regulator must be removed from service and inspected. Damaged or otherwise unsatisfactory parts must be repaired or replaced before returning the regulator to service. The set-point is the outlet pressure the regulator is adjusted to deliver.

The maximum pressure that can be safely contained by the diaphragm case is 175 psi. Safely contained means no leakage as well as no bursting.

Before using any of the above data, make sure this entire section is clearly understood.

Other Gases

The Model 441-57S Regulator is mainly used on natural gas services; however, this regulator will perform equally as well on other gases. When using the Model 441-57S Regulator on other gases, the regulator capacities must be adjusted using the following correction factors:

Type of Gas

Correction Factor

Air (specific gravity 1.0)	0.77
Propane (specific gravity 1.53)	0.63
1350 BTU Propane-Air Mixture (specific gravity 1.20)	0.71
Nitrogen (specific gravity 0.97)	0.79
Dry CO ₂ (specific gravity 1.52)	0.63

For other non-corrosive gases use the following formula:

$$\text{Correction Factor} = \sqrt{\frac{0.60}{\text{Specific gravity of the gas}}}$$

For use with gases not listed above, please contact your Sensus representative or Industrial Distributor for recommendations.

Monitoring

The Model 441-57S Regulator makes an excellent monitor. It can act as a standby regulator installed in series which assumes control if a failure in the operating regulator permits the outlet pressure to exceed the set-point. It can be located in either the upstream or the downstream position.

When a Model 441-57S Regulator is used to monitor a regulator with an identical inner valve (another 441-57S Regulator), the **total maximum capacity** through both regulators can be figured at 70% of the capacity of one regulator alone. This applies with the monitor located either upstream or downstream.

Authorized Distributor:

All products purchased and services performed are subject to Sensus' terms of sale, available at either; <http://na.sensus.com/TC/TermsConditions.pdf> or 1-800-METER-IT. Sensus reserves the right to modify these terms and conditions in its own discretion without notice to the customer.

This document is for informational purposes only, and SENSUS MAKES NO EXPRESS WARRANTIES IN THIS DOCUMENT. FURTHERMORE, THERE ARE NO IMPLIED WARRANTIES, INCLUDING WITHOUT LIMITATION, WARRANTIES AS TO FITNESS FOR A PARTICULAR PURPOSE AND MERCHANTABILITY. ANY USE OF THE PRODUCTS THAT IS NOT SPECIFICALLY PERMITTED HEREIN IS PROHIBITED.